

Radio DTMF Activator Model 14-99005V2-xyz



Application:

The LMG 14-95005V2-xyz Radio DTMF Activator provides radio-controlled relay contacts for convenient control of gates, switches and other equipment. It is equipped with 13 selectable operational modes, enabling selection of one of several variations of timed relay, toggle relay on/off, combined timed/toggle relay operation in addition to the option of separate control of two relays.

Features:

- Available in signal-rack mounting and wall-mounting versions.
- 8-channel synthesized, programmable VHF radio with channel select switch on the front panel
- Accepts DTMF codes up to six digits in length.
- Status LEDs on front panel for “Power”, “Radio Receiving”, “DTMF Decoding”, “Relay Activated.”

Operation

One of eight pre-programmed channels is selected via the channel select switch on the front panel. Choose one of the programmed operational modes. (Note: The operational mode is normally set at the factory, but can be changed in the field.) Set the time (if appropriate for mode selected) and DTMF code using rotary switches on the front of the unit.

To operate, transmit the DTMF code via VHF (or UHF) radio to the Radio DTMF Activator. For units equipped with the timed relay, the relay will remain energized until the preset time expires. If the code is re-entered during the time the relay is activated, the timer is reset and restarts the timing sequence. For units programmed for “relay on/relay off” operation, the operator enters the DTMF code followed by a “*” to energize the relay. It will remain energized until the operator enters the DTMF code followed by a “#” (or the power is removed). For units programmed for momentary actuation of the NO and NC relay contacts, entering the DTMF code followed by a “*” momentarily closes the NO contact. Entering the DTMF code followed by a “#” momentarily opens the NC contact. See “Operational Modes” for more details.

Operational Modes

The Activator has 13 modes built-in and accessible to the user. These are:

- 0) Code toggles relay. I.E. enter code to turn relay on, enter code again to turn relay off. Timer setting irrelevant.
- 1) Code alone trips relay. Timer = 1 second per increment.
- 2) Code alone trips relay. Timer = 10 seconds per increment.
- 3) Code alone trips relay. Timer = 1 minute per increment.
- 4) Code then “ * “ to turn relay on, or Code then” # “ to turn relay off. There is no timer setting.
- 5) Code then “ * “ to turn relay on, or Code then “ # “ to turn relay off. Timer = 1 sec per increment.
- 6) Code then “ * “ to turn relay on, or Code then “ # “ to turn relay off. Timer = 10 sec per increment.
- 7) Code then “ * “ to turn relay on, or Code then “ # “ to turn relay off. Timer = 1 minute per increment.
- 8) Code then “ * “ enables relay 1. Code then “ # “ enables relay 2. Timer = 1 sec per increment.
- 9) Code then “ * “ enables relay 1. Code then “ # “ enables relay 2. Timer = 10 sec per increment.
- 10) Code then “ * “ enables relay 1. Code then “ # “ enables relay 2. Timer = 1 minute per increment.
- 11) Code then “ * “ then “xxx” (enter time in seconds) I.E. to enable the relay for 19 seconds you would enter “123*019” assuming the code of the unit was “123”.
- 12) Code then “ * “ then “xxx” (enter time in minutes) I.E. to enable the relay for 27 minutes you would enter “123*027” assuming the code of the unit was “123”.

The figure to the right illustrates Jumper J4. For all modes except 8, 9 & 10, JU4 is in position A and only Relay 1 is used. In modes 8, 9 & 10, it is in position B. Relays 1 and 2 are used and energized independently.

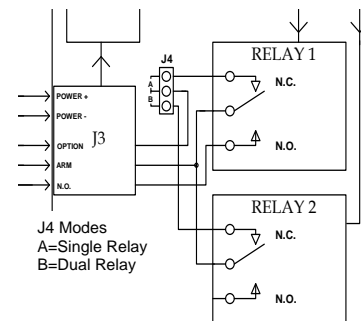

Physical Description:

The radio DTMF Activator consists of a painted steel enclosure wherein the circuit board and radio are mounted. The enclosure is mounted onto a phenolic mounting plate. Two mounting plate configurations are offered: A signal rack-mounting style with the terminals mounted at the rear and a wall mounting style, with the terminals mounted at the front of the unit. See the illustrations on the facing page. Electrical connections are made via standard AAR-type terminals.

The DTMF code and radio channel are selected via rotary switches on the front of the unit. The unit is normally provided with an antenna “shorting plug” and “50m Ohm load”. When the Activator is to be controlled by a mobile radio at short range (e.g., a hi-rail vehicle at a railroad crossing), the shorting plug or 50 Ohm load often provides adequate sensitivity. If greater sensitivity is needed, the radio has a bnc antenna connector to allow use of various antennas.

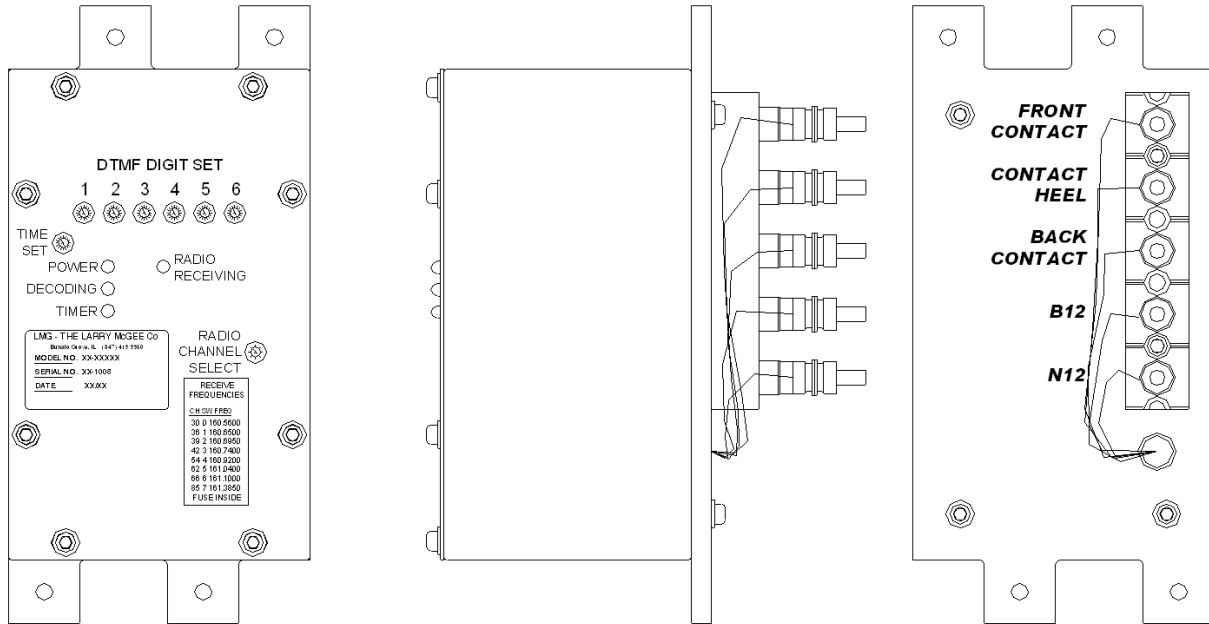

Radio DTMF Activator—Rack-Mounting Version
14-99005Ayz

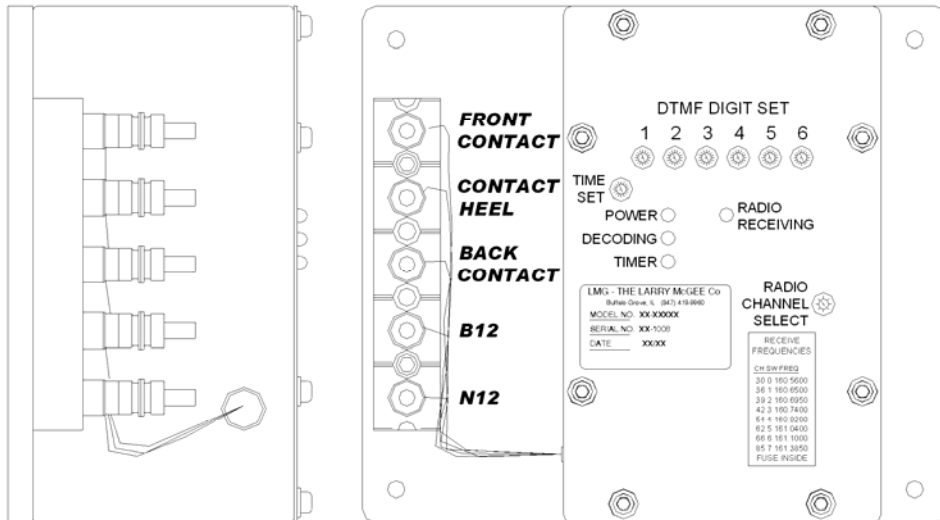

Radio DTMF Activator—Wall Mounting Version
14-99005V2-Byz

Specifications:

Input Power	8 to 35 volts DC, 160 milliamperes max. (@8 volts, lower current at higher voltages), diode protected against reversed polarity.
Radio	Programmable VHF, 8 synthesized channels. Select channel with rotary switch on front panel
Temp. Range	Operational: -30C (-22F) to +60C (+140F) Storage: -40C (-40F) to +80C (+176F).
Size	Relay-Rack mounting version, overall dimensions are 4 3/4 x 9 3/4" x 7". Wall-mounting version, overall dimensions are 8 3/4" x 7 3/4" x 4 3/8".
Weight	5 pounds.
Isolation	Tested to 2000 VAC between case and each terminal. Connecting an antenna with a grounded shield WILL ground the power supply negative. The user must determine electrical isolation requirements for each installation.
Surge Protection	1500 Watt, 36 Volt TVS between Power and Ground.
Relay Contacts	Relay contact rated 1 amp @ 30 VDC. One "Form C" contact available. ("Front contact", "Back Contact" and "Contact Heel").
Terminals	Standard 1/4" signal-type terminals for power and relay contacts.
DTMF Code	1-6 digit, selected with rotary switches on front panel.
Relay Timer	Timer set with rotary switch on front panel. Timer ranges, depending on mode, are: 1—15 seconds, 10—150 seconds and 10—150 minutes.

Ordering Information:

In order for us to configure your Radio DTMF Activator appropriately, we need certain information at the time of ordering:

- (1.) Mounting method (either signal rack or wall mounting),
- (2.) Operational Mode,
- (3) Frequency band and model of radio desired and
- (4.) A list of up to eight radio frequencies (and/or AAR Channels) to be programmed into the radio.

The first three items are incorporated into the part number (see below)

Radio DTMF Activator Part Numbering:

14-99005V2-xyz Radio DTMF Activator

Options: "x" - Mounting method, A = Signal Rack Mounting, B = Wall Mounting

"y" Operational Mode, choose one of Operational Modes 0—12

"z" Radio: D=Ritron DTX Plus, VHF; E=Ritron DTX Plus, UHF;

J=CalAmp JSLM2 VHF; K=CalAmp JSLM2 UHF.

Examples of part numbering:

14-99005V2-A2D Radio DTMF Activator, Signal Rack Mounting

14-99005V2-B7J Radio DTMF Activator, Wall Mounting